



ALL IN ONE
E-MOBILITY

Grinding-Automation-Superfinishing-Cleaning-Post process measuring
Complete machining of rotor shafts
with **Corundum** and/or **CBN**



- CNC grinder for **external cylindrical grinding**
- Workpieces up to **600 mm** in length and max. **8 kg**
- **Grinding of:**

Diameters

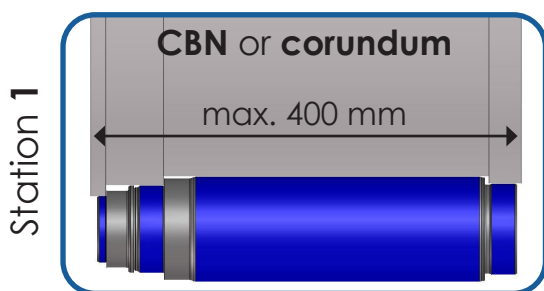

Corundum: \varnothing 750x400 mm / 28 sec.
Ceram. CBN: \varnothing 750x400 mm / 20 sec.

Flat surfaces

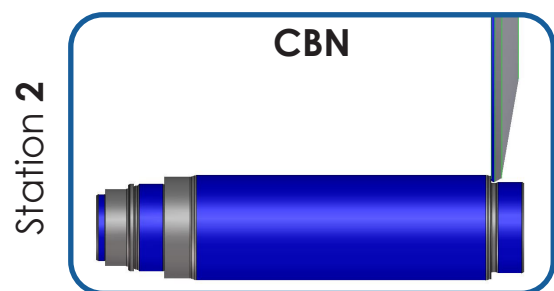

Ceram. CBN: \varnothing 500 mm / 10 sec.

- Automatic loading by means of **GST+** loading system
- Numerous operations in just one machine - **ALL IN ONE**
- Applications via a control system - „**Siemens ONE**“
- **Extremely easy changeover** due to dragging of measuring devices & automatic adjustment of the work headstock due to the workpiece length
- Post-process measuring, superfinishing and automation **without makeready**



Technologies

AUTOMATION

GRINDING

SUPER-FINISHING

CLEANING

POST PROCESS MEASURING

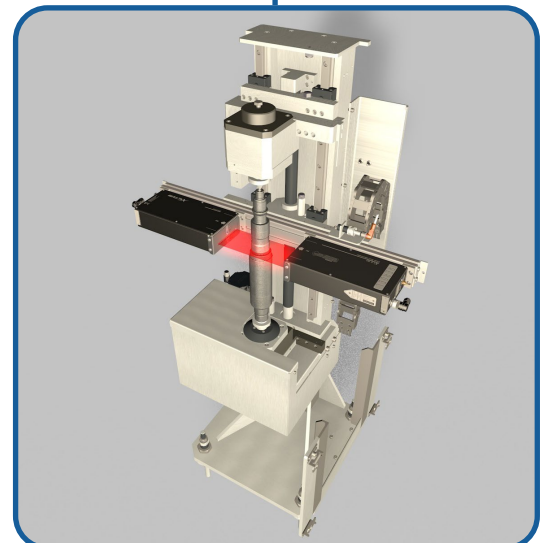
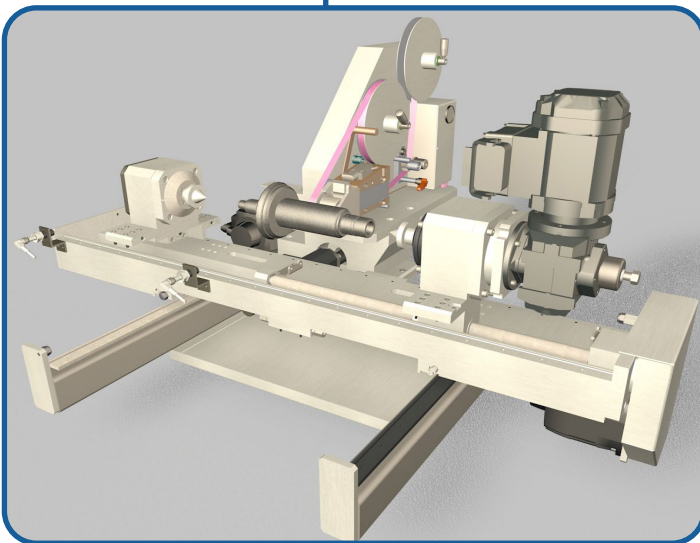

Added value due to **GST+** products

- **GST** grinding spindle / **GST** dressing spindle
- **GST** electric slide
- **GST** loading system
- **GST** post process measuring station
- **GST** superfinishing station
- **GST** grinding wheel handling
- **GST** cylinder compensation
- **GST** rotating tailstock insert